

21.5" FHD Medical Touchscreen Display

FS-E2102DT



Crystal Clear Full High Definition Images

This touchscreen medical display is ideal for controlling a user interface, or manipulating images in applications that incorporate endoscopic cameras, ultrasound, cardiology, room or boom cameras, patient vital signs, and more. It displays images with near zero latency, and is compatible with major MIS camera systems in use.



User Friendly

FS-E2102DT features an intuitive, on-screen menu for image and layout settings. Multi-modality options let doctors view PIP, PBP, or triple images at the same time. The rounded monitor housing corners help protect OR personnel from accidental bumping injuries. Its lightweight design is ideal for boom or spring-arm mounting, and the front surface is edge-to-edge glass for fast, easy cleaning.

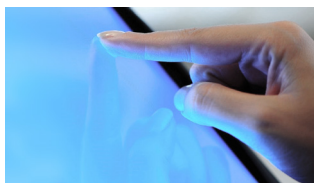

Fingertip Control

FS-E2102DT is a projected capacitive multi-touch screen that is designed for medical applications, including complex user interfaces.



The touchscreen offers convenient data and image control for clinicians. It features a high brightness LED back light and rich color calibration for FHD medical grade image consistency. Like other FSN displays, this model has a complete set of features designed for presenting images from sophisticated medical video equipment.

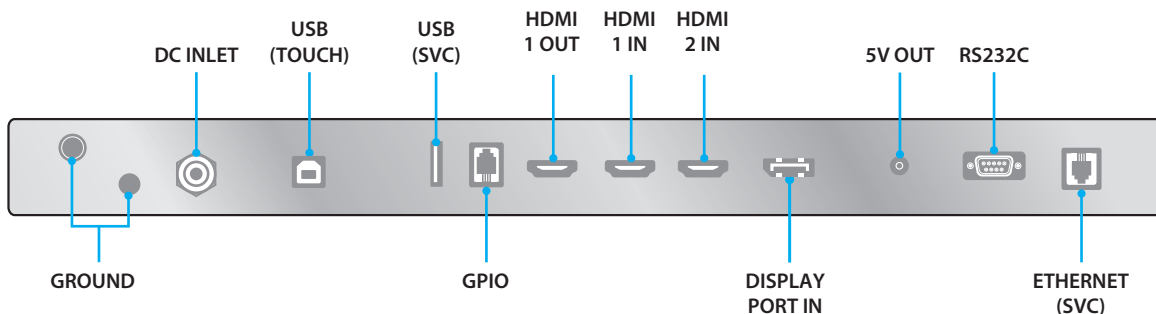
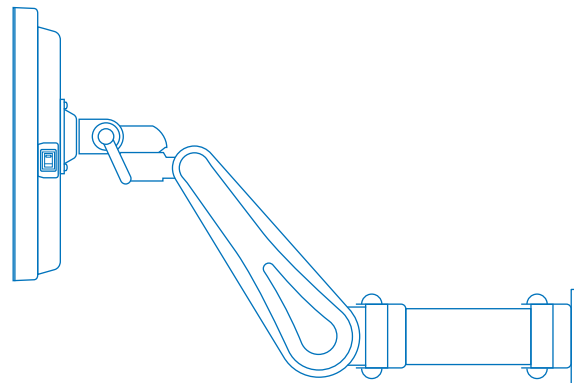
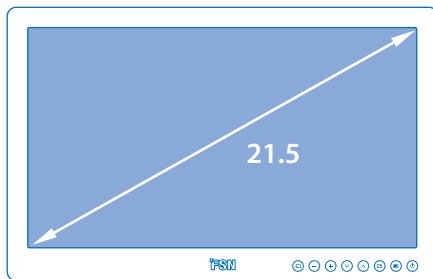

fsnmed.com

Foreseeson Custom Displays, Inc.

2210 E. Winston Road
Anaheim, CA 92806 USA
Tel: 714-300-0540
Fax: 714-300-0546

Latin America
Aventura, FL 33180 USA
Tel: 714-507-3855

Foreseeson Korea

B-408, U-Space2
670 Daewangpangyo-ro,
Bundang-gu, Seongnam-si
Gyeonggi-do, Republic of Korea
Tel: +82-31-8017-0780

Foreseeson GmbH

Industriestrasse 38a
63150 Heusenstamm, Germany
Tel: +49 6104 64398 0
Fax: +49 6104 64398 11

Foreseeson UK Ltd.

1 Wolsey Road
East Molesey
Surrey
KT8 9EL
United Kingdom
Tel: +44 (0) 208 546 1047

Foreseeson (Shanghai)

Medical Equipment Co., Ltd.
Room 1010, Building A
1439 Wuzhong Road
Rhein Hongjing Center
Minhang District, Shanghai, China
Tel: 18521095596

21.5" FHD Medical Touchscreen Display

FS-E2102DT



Specifications

General Features

Item	Description
Panel	21.5 inch TFT LCD (LED)
Resolution	1920 x 1080 pixels
Aspect Ratio	16 : 9
Active Area	476.06(H)mm x 267.79(V)mm
Touchscreen	10 point projected capacitive USB (2.0)
Pixel Pitch (mm)	0.2479 x 0.2479
Response Time (typical)	22 ms (rise and fall)
Number of Colors	16.7 million
Brightness (typical)	300 cd/m ²
Gamut	BT.709 calibrated
Contrast Ratio (typical)	1000 : 1
Surface Treatment	Anti-reflection, anti-fingerprint
Viewing Angle (CR>10)	R/L 178°, U/D 178°
Input Signal	2 x HDMI (1.4) 1 x DP (1.2)
Output Signal	1 x HDMI (1.4)
Power Supply	AC/DC Adaptor (AC 100~240V, DC 12V 5A)

Item	Description
Power Consumption	45W max
Latency (typical)	2 ms max
Accessories Included	User manual, AC-DC adaptor, AC power cord, HDMI cable, USB cable, Screw BH M4 x 14
Unit Dimension	527.9(W) x 334.5(H) x 58.9(D) mm 20.78(W) x 13.17(H) x 2.32(D) inch
Package Dimension	667(W) x 580(H) x 163(D) mm 26.26(W) x 22.83(H) x 6.41(D) inch
IP Rating	IP33 - overall
Weight	5.5 kg, 12.12 lbs. (monitor) 8.48 kg, 18.69 lbs. (shipping package)
Certifications	ANSI/AAMI ES60601-1(UL60601-1), CAN/CSA C22.2 No. 60601-1, FCC Class B, EN60601-1, EN60601-1-2, CE, MDR(EU) 2017/745 Class I Medical Device

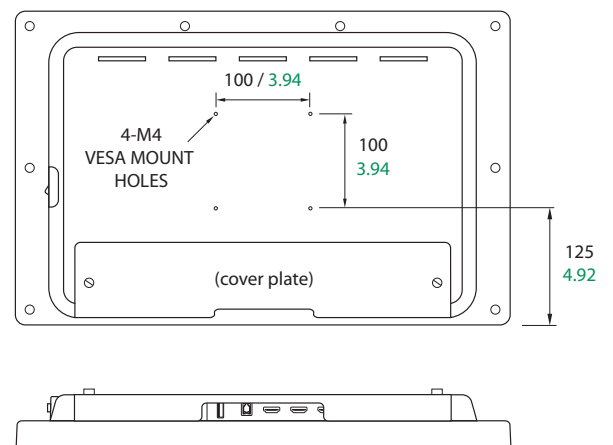
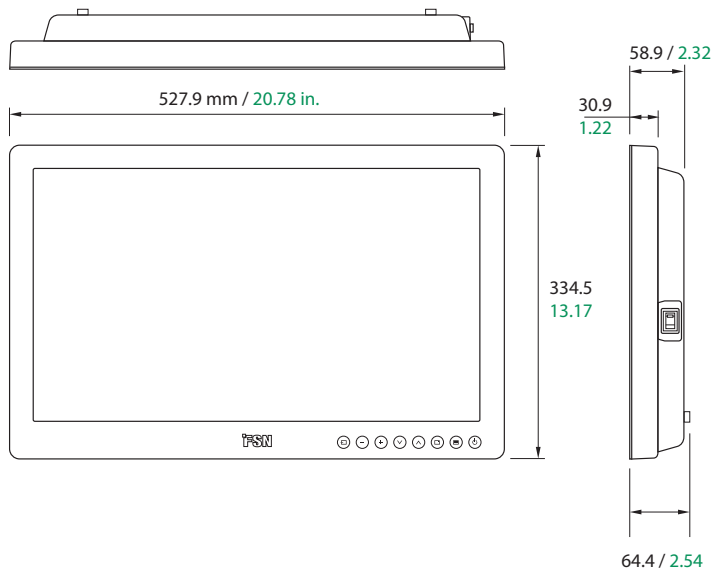

FSN Medical Technologies products meet EU RoHS Directive 2011/65/EU+2015/863/EU and Registration, Evaluation, Authorisation and Restriction of Chemicals (REACH) obligations. FSN manages the information flow as required by regulations.

Specifications are subject to change with or without notice. Doc. # FSN2081 Rev. 2/24

Nirolo Professional Displays
Ippelseweg 15-b
4255 HW, Nieuwendijk
The Netherlands
+31 (0) 183 50 50 64
info@nirolo.nl

